

1 主要参数 (Main Items)

1.1 光学参数规格 (Optical Specifications)

NO.	项目 (Items)	Specification						
1	F No.	0.95±5%						
2	焦距(Focal-Length)	4 ±5%						
3	光学后焦 (Optical Back Focal Length)	5.72±0.1 (in air)						
4	机械后焦 (Mechanical Back Focal Length)	5.58±0.2 (in air)						
5	镜头总长(TTL)	31.96±0.2 (in air)						
6	像面大小 (Image circle)	Φ6.6(1/2.7") (MAXΦ6.9)						
7	镜片构成 (Lens structure)	5G4P						
8	接口 (Mount)	M16*P0.5						
9	镜头与底座螺纹配合扭力 (Clamp Force)	60-600gf-cm						
10	视场角(FOV)	sensor型号	H(水平)		V(垂直)		D(对角)	
		1/2.7"	92.3° ±5%		48.7° ±5%		109.9° ±5%	
		1/2.8"	88.4° ±5%		47° ±5%		105.2° ±5%	
		1/2.9"	84.8° ±5%		45.3° ±5%		100.5° ±5%	
11	光学畸变 (Optical Distortion)	1/2.7"	-40.8%	1/2.8"	-37.5%	1/2.9"	-34.4%	
12	相对亮度 (Relative Illumination)	1/2.7"	59.0%	1/2.8"	60.0%	1/2.9"	63.0%	
13	最大主光线夹角 (CRA)	1/2.7"	8.3°	1/2.8"	8.1°	1/2.9"	7.8°	
14	近摄距 (M.O.D)	0.2m						
15	解像标准 (Resolution)	分辨率 (Resolution): 1920×1080 (2MP)						
		投影出: 中心: 160本清晰;ø4.5:125本清晰; ø6:63本线条分开, 1/2拖影即可; center:160lp/mm clear;ø4.5:125lp/mm clear; ø6:63lp/mm lines separate apart, 1/2 smear						
16	重量 (Weight)	19.6g						
17	操作方法 (Operation)	聚焦 (Focus)	自动 (AUTO)					
		光圈 (Iris)	固定 (Fixed)					
18	环保&安全 (HSF&Safety)	RoHS						

1.2 机构参数规格 (Mechanical Specifications)

1.2.1 外形尺寸图 (Dimension Figure)

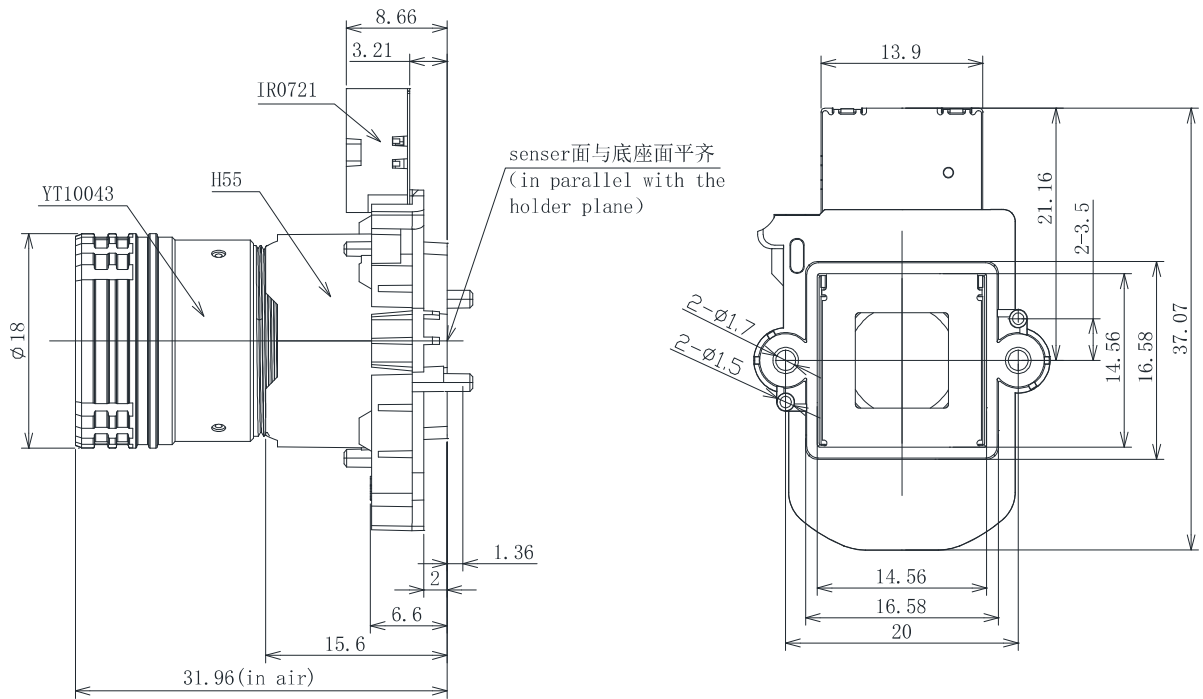

1.2.2 视点图 (Viewpoint Figure)

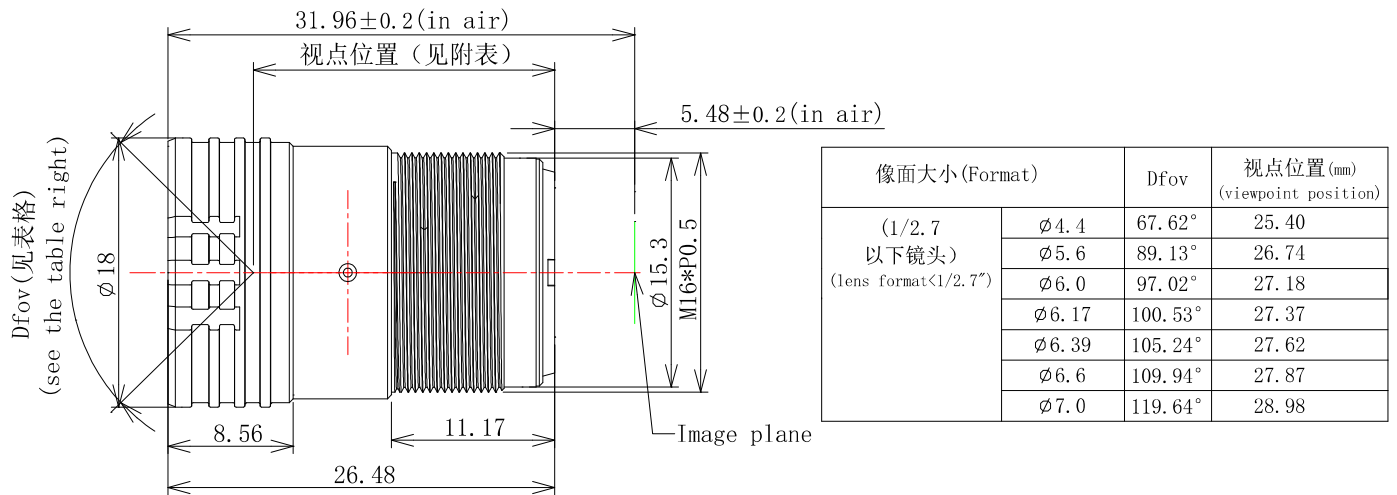

本规格书未注单位 (Unit is not indicated in the document): mm
未注公差 (Unmarked Tolerance): $\Phi \pm 0.1$, $L \pm 0.15$