



InnoMaker CAM-MIPI7251RAW
--Low Cost Global Shutter Camera
--Software External Trigger
--Hardware External Trigger

CAM-MIPI7251RAW User Manual



Normally We will update our development Manual here
<https://github.com/INNO-MAKER/cam-mipiov7251-trigger>



InnoMaker CAM-MIPI7251RAW

--Low Cost Global Shutter Camera

--Software External Trigger

--Hardware External Trigger

Revision History

Date	Version	Details
2022-10-27	V1.0	Correct Chapter 2.3 Mode Description
2022-11-23	V1.1	Add method about install header files
2023-04-04	V1.2	Add Innocam SDK Description
2023-05-31	V1.3	Add Python demo of chapter
2023-06-01	V1.4	Correct Python Code



Catalogue

CAM-MIPI7251RAW User Manual 1

Chapter 1 Hardware Description: 4

 1.1 Features 4

 1.2 Camera LEN 5

 1.3 Signal/Power Connector J1 5

 1.4 STROB Connector J2 6

 1.5 EXT TRIG Connector J3 7

Chapter 2 Innomaker Driver Install Guide 9

 2.1, Download Source Code 9

 2.2, Install kernel headers 9

 2.3, Compile the driver source code 10

 2.4, Install driver 10

 2.5, System Setting 10

 2.6, **Working Mode** 11

 2.7, Video Capture And Preview 12

Chapter 3 PI OS Driver Install Guide 16

 3.1 Edit config.txt file 16

 3.2 Edit cmdline.txt file 16

 3.2 Check camera status 16

 3.2 Install python and opencv 17

 3.3 Run python demo 17

Chapter 1 Hardware Description:

1.1 Features

- 1, Active array size: 640x480, **Global Shutter, External Trigger.**
- 2, Output formats: 8bit RAW BW and 10 bit RAW BW.
- 3, Frame rate: 158fps.
- 4, Optical coupled isolated external trigger input and flash output support
- 5, Support 4 work mode:
 - **0, 10 bit stream mode**
 - 1, 8 bit stream mode
 - **2, 10 bit external trigger mode**
 - **3, 8 bit external trigger mode**
 Work on 8bit stream mode by default.
- 6, Software trigger input support.
- 7, driver feature support: gain,exposure,hflip,vflip

Board Size

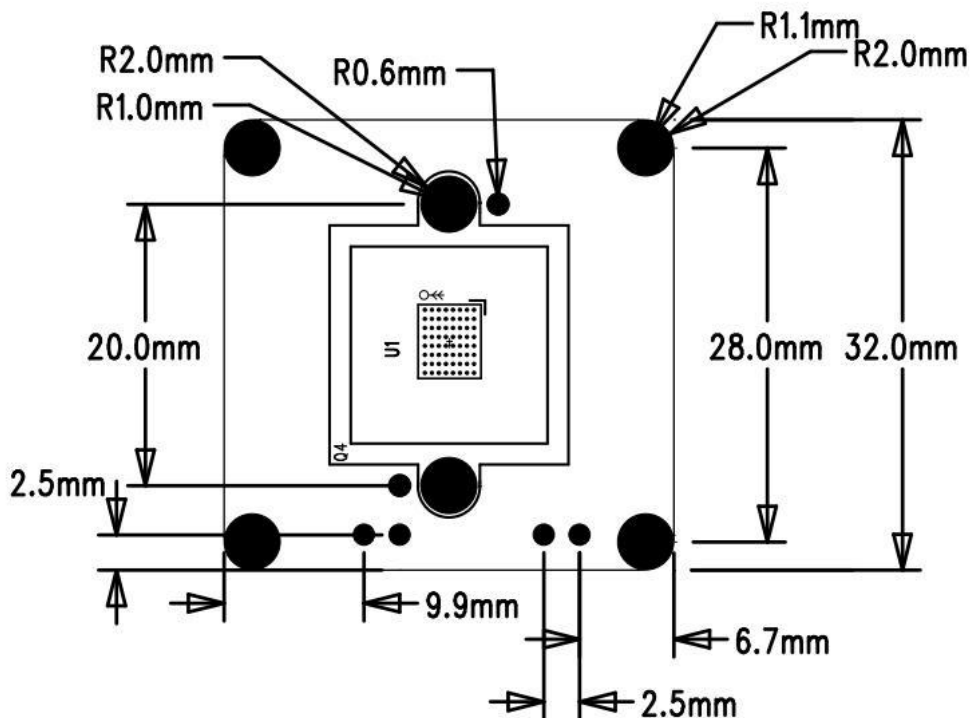



InnoMaker CAM-MIPI7251RAW
--Low Cost Global Shutter Camera
--Software External Trigger
--Hardware External Trigger

1.2 Camera LEN

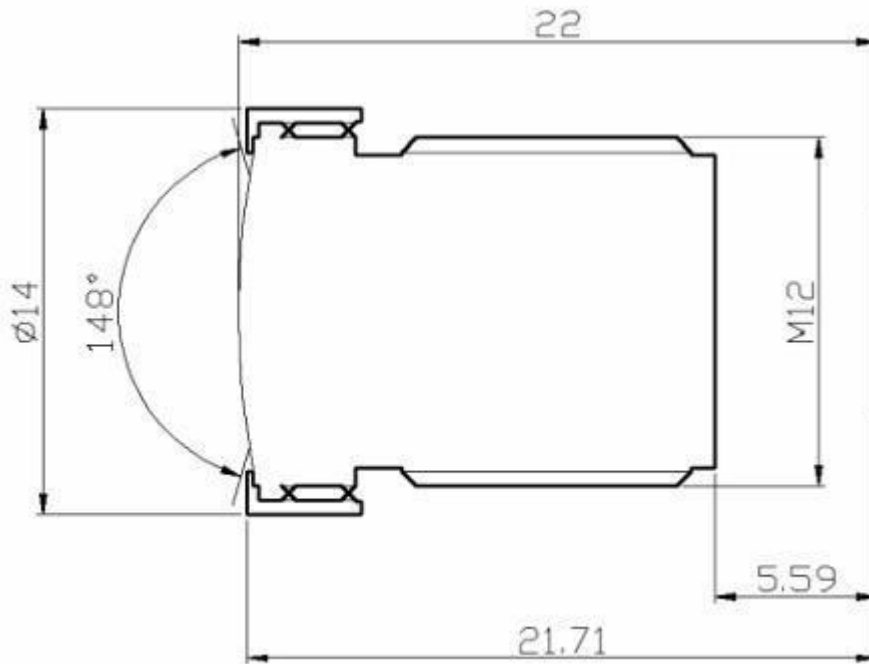

- Interface: M12
- Field of view Fov(D) = 148 degrees , Fov(H) = 118 degrees
- Focal Length 2.8 mm
- Focal Distance Adjustable
- TV DISTORTION < -17%
- F(N) /Aperture 2.2

1.3 Signal/Power Connector J1

- Low Cost Global Shutter Camera
- Software External Trigger
- Hardware External Trigger

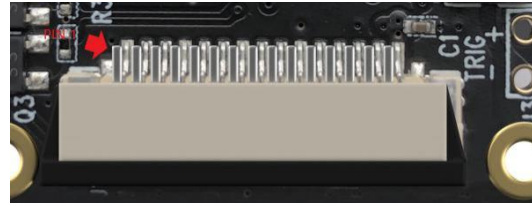
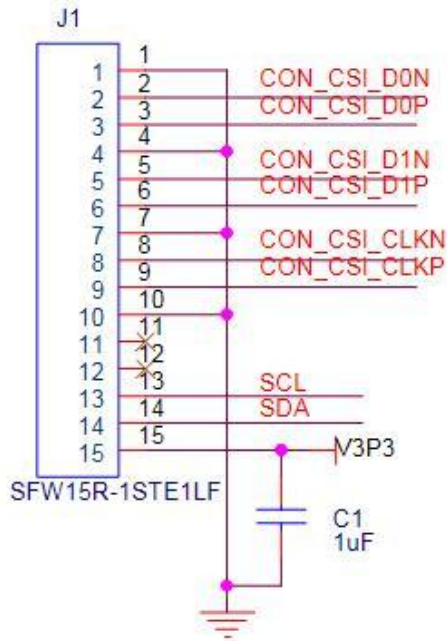

1.4 STROB Connector J2

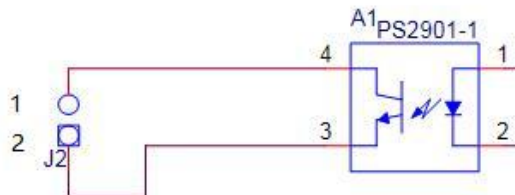

ISO FLASH

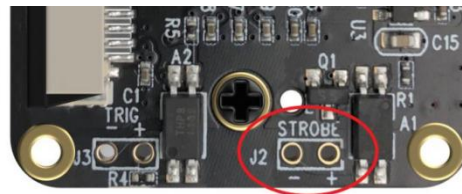

J2 PIN	Symbol
1	STROB+
2	STROB-

1.4.1 Reference Circuit

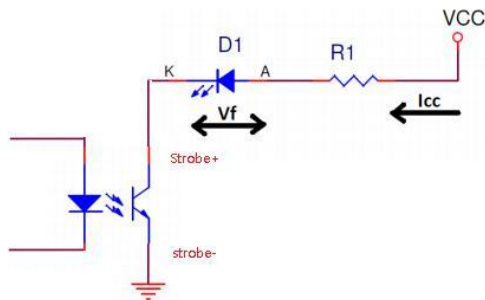

On-board TLP281 optocoupler isolation, Notice the max collector current is 50mA.

Output Specifications

S. No	Parameter	Test Condition	Value			Unit
			Min	Typ	Max	
1	Driver Voltage (VCC)			12	24	V
2	Drive current (Icc)			10	50	mA
3	Collector Emitter Breakdown Voltage				80	V
4	Collector Emitter Saturation Voltage	Icc = 1 mA		0.1	0.2	V
5	Power Dissipation				150	mW

Collector-Emitter Saturation Voltage	$V_{CE(sat)}$	$I_F = 10mA, I_C = 1mA$		0.1	0.2	V
--------------------------------------	---------------	-------------------------	--	-----	-----	---

So If the current required to drive the Flash LED is no more than 50mA

The value of series resistor: $R1 = (VCC - Vf - VCE) / If$

VCC: system Voltage

Vf: Forward voltage of Flash LED for current Icc

VCE: Collection Emitter voltage, typical:0.1V

If the current required to drive the flash exceeds 50mA, then it is required to drive it with the help of LED driver circuit, and LED driver circuit can be controlled by using the strobe output pin.

1.5 EXT TRIG Connector J3

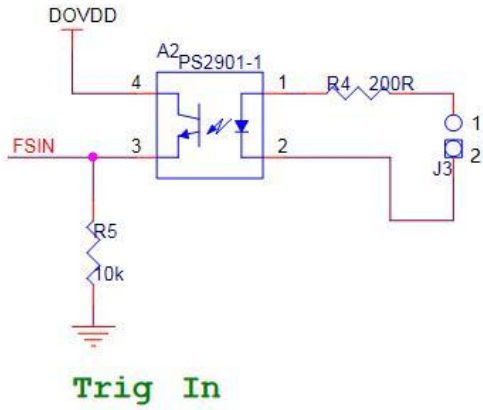

J3 PIN	Symbol	Description
1	TRIG+	3.3V-5.0V External Trigger Input
2	TRIG-	External GND

1.5.1 Reference Circuit

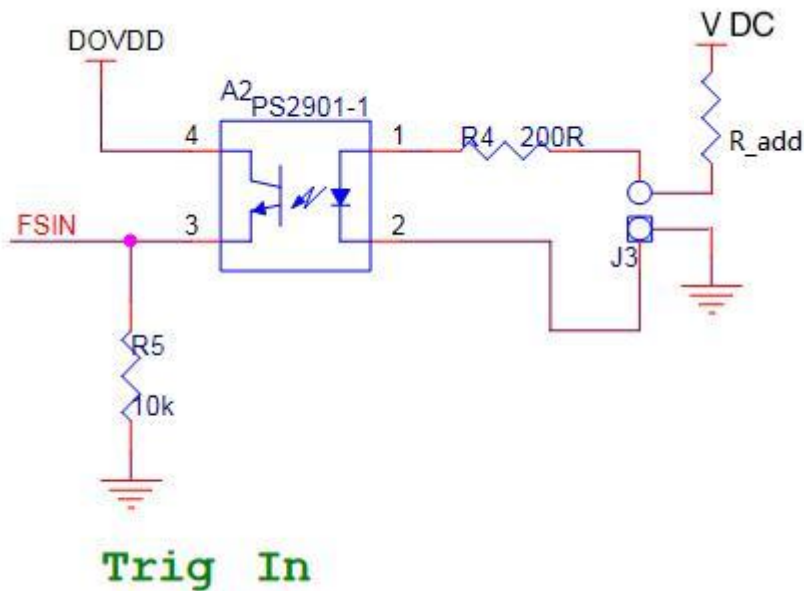

For example, VCC = 12V, Vf = 1.25V



Raspberry PI Global Shutter Camera
Support Software External Trigger
Support Hardware External Trigger

The calculations done here are based on 12VDC. Please do follow these calculations for other voltages like 24VDC.

Let's take the current through IR LED $I_f = 20\text{mA}$.
Voltage drop across the IR LED = 1.25V
The value of Resistor $R_1 = (V_{cc} - V_f) / I_f = (12 - 1.25) / 0.02 = 537.5 \Omega$
Wattage of resistor $R_1 > I_f^2 * R_1 = 0.02^2 * 537.5 = 0.215\text{W}$
Wattage of the resistor R_1 selected should be greater than 0.215W.

And there is a resistor on board ($R_4 = 200 \Omega$), So the $R_{add} = R_1 - R_4 = 537.5 - 200 = 337.5 \Omega$

Chapter 2 Innomaker Driver Install Guide

Compare to raspberry pi os driver,
Innomake driver support external hardware and software trigger and stobe function, 153fps than 30fps.

2.1, Download Source Code

```
$sudo git clone https://github.com/INNO-MAKER/cam-mipiov7251-trigger.git
```

2.2, Install kernel headers

If you are using the latest version of Raspbian, Install the Linux kernel headers via below command.

```
$sudo apt-get install raspberrypi-kernel-headers
```

Remark:

If you are use the older version of Raspbian or unable to locate package, manually download the correct headers files from below link. We take kernel 5.15.32-v8+(64bit, released data 2020-0404) as an example.

<https://archive.raspberrypi.org/debian/pool/main/r/raspberrypi-firmware/>

 raspberrypi-kernel-headers_1.20220331-1_amd64.deb	2022-04-04 12:55	37M
 raspberrypi-kernel-headers_1.20220331-1_arm64.deb	2022-04-04 12:55	9.2M
 raspberrypi-kernel-headers_1.20220331-1_armhf.deb	2022-04-04 12:56	27M

Use dpkg tools install the headers deb files via below command.

```
$sudo dpkg -i raspberrypi-kernel-headers_1.20220331-1_arm64.deb
```



Raspberry PI Global Shutter Camera
Support Software External Trigger
Support Hardware External Trigger

2.3, Compile the driver source code

```
$cd cam-mipiov7251-trigger  
$sudo chmod -R a+rw *  
$cd ov7251_driver_source_code/source_code  
$sudo make
```

2.4, Install driver

```
$sudo make install #Work on 8bit stream mode by default.
```

2.5, System Setting

5.1 For PI4/PI3+/PI3/PI2

edit /boot/config.txt

```
$sudo nano /boot/config.txt
```

Add below content to the last line and reboot

```
dtoverlay=innomipi_ov7251
```

Reboot

```
$sudo reboot
```

5.2 For CM4/CM3+/CM3 Dual Camera

Copy dtbo file to /boot/overlays and point it as default device.

```
$ sudo cp ov7251_driver_source_code/innomipi_ov7251_cm4_dual.dtbo /boot/overlays
```

Add below content to the last line save and reboot

Edit /boot/config.txt

```
$ sudo nano /boot/config.txt  
$ dtoverlay=innomipi_ov7251_cm4_dual
```



Raspberry PI Global Shutter Camera
Support Software External Trigger
Support Hardware External Trigger

```
$sudo reboot
```

For PI Zero/PI Zero W

edit /boot/config.txt

```
$sudo nano /boot/config.txt
```

Add below content to the last line and reboot

```
dtoverlay=innomipi_ov7251, i2c_pins_28_29=1
```

Reboot

```
$sudo reboot
```

Step5, Check driver install status

```
$ls /dev/video*
```

```
pi@raspberrypi:~$ ls /dev/video*  
/dev/video8 /dev/video11 /dev/video13 /dev/video15 /dev/video16 /dev/video17 /dev/video18 /dev/video19 /dev/video20 /dev/video21 /dev/video22 /dev/video23 /dev/video24 /dev/video25 /dev/video26 /dev/video27 /dev/video28 /dev/video29  
pi@raspberrypi:~$
```

2.6, Working Mode

2.6.1 Working Mode Description

Mode	Description	array	Frame rate
0	10bit stream mode	640x480	158fps
1	8bit stream mode	640x480	158fps
2	10bit external trigger mode	640x480	EXT_TRIG
3	8bit external trigger mode	640x480	EXT_TRIG

2.6.2 Working Mode Selection Method

```
$cd cam-mipiov7251-trigger/innomipi_ov7251_driver_pi_lattice_linux5.15  
$sudo make setmodex # x can be 0 1 2 3
```



Raspberry PI Global Shutter Camera
Support Software External Trigger
Support Hardware External Trigger

Get camera module work mode information:

```
$ modinfo inno_mipi_ov7251
```

2.6.3 Software Trigger Mode

Step1 : set camera work in external trigger mode.

For example set the module work in mode3

```
$ sudo make setmode3
```

Open /dev/video0 device in VLC

Step2: Transfer software trigger command through i2c bus

```
$ i2cset -f -y 10 0x10 204 1
```

Remark:

*** Set the sensor module back to external hardware trigger mode by:

```
$ i2cset -f -y 10 0x10 204 0
```

2.6.4 Hardware Trigger Working Mode

*** Set the sensor module back to external hardware trigger mode by:

```
$ i2cset -f -y 10 0x10 204 0
```

2.7, Video Capture And Preview

2.7.1 VLC Capture Function

Open VLC And Choose /dev/video*



Raspberry PI Global Shutter Camera
Support Software External Trigger
Support Hardware External Trigger

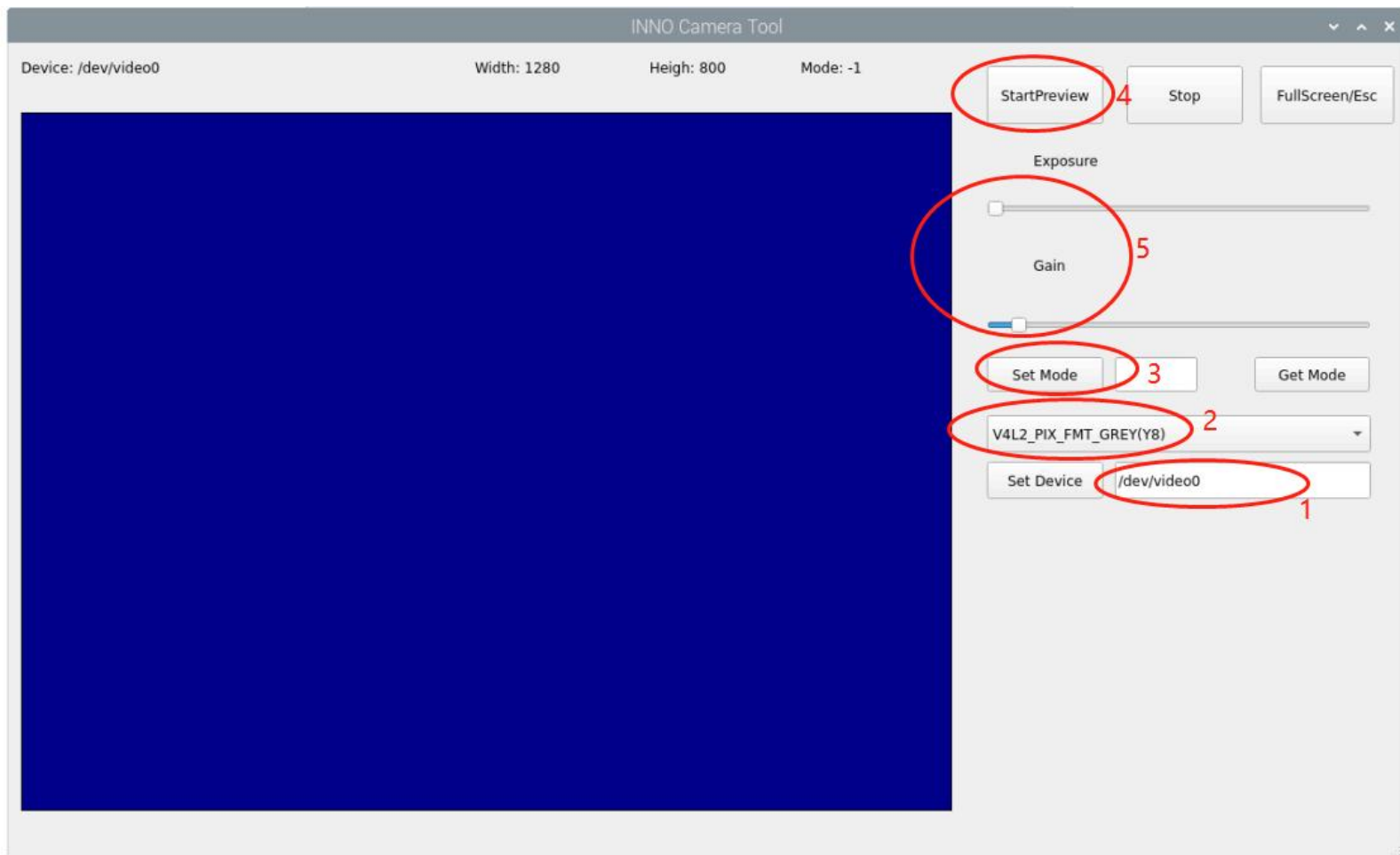

- 1, Check if video0 exist;
- 2, Choose Y8 Mode
- 3, Set working mode as 1
- 4, Press StartPreview button
- 5, Adjust Exposure and Gain value according to working scene.

2.7.3.1 Wire connection

You can connect the TRIG- to the GND Pin and connect the TRIG+ to 3.3V Pin of Raspberry Pi to simulate a trigger signal. This test function will come with repeated trigger signal sometime.

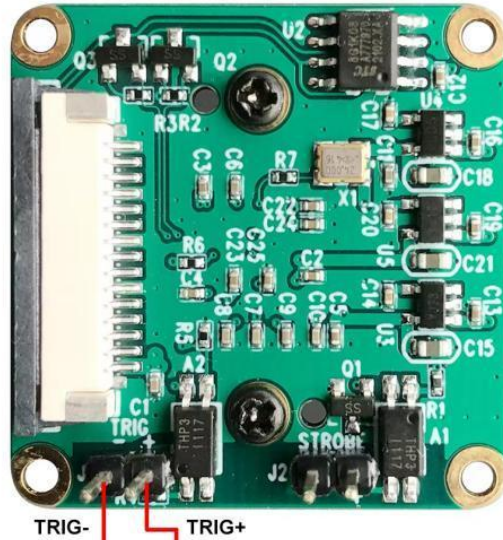

3V3	(1)	(2)	5V
GPIO2	(3)	(4)	5V
GPIO3	(5)	(6)	GND
GPIO4	(7)	(8)	GPIO14
GND	(9)	(10)	GPIO15
GPIO17	(11)	(12)	GPIO18
GPIO27	(13)	(14)	GND
GPIO22	(15)	(16)	GPIO23
3V3	(17)	(18)	GPIO24
GPIO18	(19)	(20)	GND
GPIO9	(21)	(22)	GPIO25
GPIO11	(23)	(24)	GPIO8
GND	(25)	(26)	GPIO7
GPIO0	(27)	(28)	GPIO1
GPIO5	(29)	(30)	GND
GPIO6	(31)	(32)	GPIO12
GPIO13	(33)	(34)	GND
GPIO19	(35)	(36)	GPIO16
GPIO26	(37)	(38)	GPIO20
GND	(39)	(40)	GPIO21

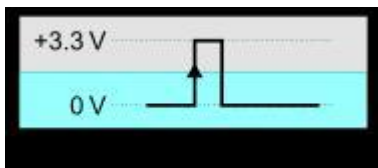

Step1 : set camera work in external trigger mode.

For example set the module work in mode3

```
$ sudo make setmode3
```

Open /dev/video0 device in VLC

Step2: Put external trigger signal through TRIG pin head.

2.7.3.2 Give 3.3V GPIO Trigger Signal to J1

For example a 3.3v gpio rising edge signal will trigger the frame output.



Raspberry PI Global Shutter Camera
Support Software External Trigger
Support Hardware External Trigger

```
$cd cam-mipiov7251-trigger/2-Tools  
$sudo ./gpio-sysfs
```

Chapter 3 PI OS Driver Install Guide

Raspberry Pi OS Support OV7251 Sensor default, compare to inno-maker driver, Raspberry Pi OS Driver is without external hardware and software trigger and strobe function.

3.1 Edit config.txt file

Enable the official driver by edit /boot/config.txt

```
$sudo nano /boot/config.txt
```

add below content and save

```
dtoverlay=ov7251,media-controller=0
```

Ctrl+X to save file.

3.2 Edit cmdline.txt file

Enable the official driver by edit /boot/config.txt

```
$sudo nano /boot/cmdline.txt
```

add below content and save

```
cma=128M
```

Ctrl+X to save file, reboot your system.

3.2 Check camera status

```
$ls /dev/video*
```

```
$vcgencmd get_camera
```

After system reboot, check video status.

```
pi@raspberrypi:~/Desktop/python sample $ vcgencmd get_camera  
supported=1 detected=0, libcamera interfaces=1  
pi@raspberrypi:~/Desktop/python sample $ ls /dev/video*  
/dev/video0 /dev/video11 /dev/video13 /dev/video15 /dev/video18 /dev/video20 /dev/video22 /dev/video31  
/dev/video10 /dev/video12 /dev/video14 /dev/video16 /dev/video19 /dev/video21 /dev/video23
```



Raspberry PI Global Shutter Camera
Support Software External Trigger
Support Hardware External Trigger

3.2 Install python and opencv

Before using the python demo, you need to install python3 and opencv package

```
$sudo apt install -y python3-opencv
```

```
$sudo apt install -y opencv-data
```

3.3 Run python demo

```
$cd cam-mipiov7251-trigger/2-Tools/
```

```
$sudo python3 demo1.py
```

```
$sudo python3 demo2.py
```